

**SK-GSK Präzisions-Spannzangenfutter**  
*SK-GSK High Precision Collet Chuck*

MAX  
45,000  
min<sup>-1</sup>

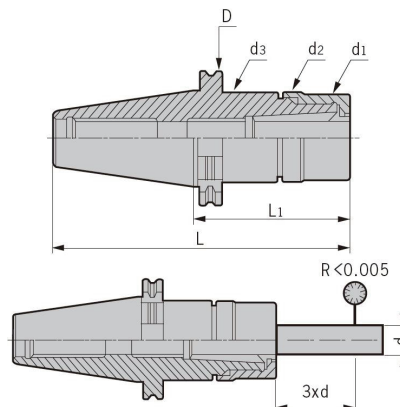

Einheit/Unit (mm)

Artikel Item	Bereich Range	D	d1	d2	d3	L1	L	Geeignete Schraubenmutter Suit nut	Gewicht Weight	
SK30-	GSK6-70	0,7-6,0	50	19,5	20,5	20,5	70	117,8	GSK6	0,45
	GSK6-100	0,7-6,0	50	19,5	20,5	32	100	147,8	GSK6	0,64
	GSK10-70	1,75-10,0	50	27	29	29	70	117,8	GSK10	0,45
	GSK10-100	1,75-10,0	50	27	29	29	100	147,8	GSK10	0,64
	GSK16-100	2,75-16,0	50	40	41,9	41,9	100	147,8	GSK16	0,90
	GSK16-120	2,75-16,0	50	40	41,9	41,9	120	167,8	GSK16	1,00
	GSK16-150	2,75-16,0	50	40	41,9	41,9	150	197,8	GSK16	1,12
	GSK20-100	3,5-20	50	48,5	50	50	100	147,8	GSK20	1,10
	GSK25-100	16,0-25,4	50	54,5	56,1	56,1	100	147,8	GSK25	1,20
SK40-	GSK6-70	0,7-6,0	63,55	19,5	20,5	20,5	70	138,4	GSK6	1,05
	GSK6-100	0,7-6,0	63,55	19,5	20,5	32	100	168,4	GSK6	1,25
	GSK6-120	0,7-6,0	63,55	19,5	20,5	32	120	188,4	GSK6	1,39
	GSK10-70	1,75-10,0	63,55	27	29	29	70	138,4	GSK10	1,20
	GSK10-100	1,75-10,0	63,55	27	29	40	100	168,4	GSK10	1,30
	GSK10-120	1,75-10,0	63,55	27	29	40	120	188,4	GSK10	1,42
	GSK10-150	1,75-10,0	63,55	27	29	40	150	218,4	GSK10	1,55
	GSK16-70	2,75-16,0	63,55	40	41,9	41,9	70	138,4	GSK16	1,21
	GSK16-100	2,75-16,0	63,55	40	41,9	41,9	100	168,4	GSK16	1,42
	GSK16-120	2,75-16,0	63,55	40	41,9	41,9	120	188,4	GSK16	1,61
	GSK16-150	2,75-16,0	63,55	40	41,9	41,9	150	218,4	GSK16	1,80
	GSK20-70	3,5-20	63,55	48,5	50	50	70	138,4	GSK20	1,50
	GSK20-100	3,5-20	63,55	48,5	50	50	100	168,4	GSK20	1,70
	GSK20-120	3,5-20	63,55	48,5	50	50	120	188,4	GSK20	1,85
	GSK20-150	3,5-20	63,55	48,5	50	50	150	218,4	GSK20	1,95
GSK25-100	16,0-25,4	63,55	54,5	56,1	56,1	100	168,4	GSK25	1,81	
GSK25-120	16,0-25,4	63,55	54,5	56,1	56,1	120	188,4	GSK25	2,05	
SK50-	GSK10-105	1,75-10,0	97,5	27	29	29	105	201,75	GSK10	3,78
	GSK10-135	1,75-10,0	97,5	27	29	32	135	221,75	GSK10	3,85
	GSK10-165	1,75-10,0	97,5	27	29	32	165	251,75	GSK10	4,33
	GSK16-100	2,75-16,0	97,5	40	41,9	41,9	100	201,75	GSK16	3,93
	GSK16-125	2,75-16,0	97,5	40	41,9	41,9	125	221,75	GSK16	4,10
	GSK16-150	2,75-16,0	97,5	40	41,9	50	150	251,75	GSK16	4,49
GSK16-200	2,75-16,0	97,5	40	41,9	52	200	301,75	GSK16	5,62	

**SK-GSK Präzisions-Spannzangenfutter**  
*SK-GSK High Precision Collet Chuck*

Einheit/Unit (mm)

Artikel Item	Bereich Range	D	d1	d2	d3	L1	L	Geeignete Schraubenmutter Suit nut	Gewicht Weight	
SK50-	GSK20-100	3,5-20	97,5	48,5	50	50	100	201,75	GSK20	4,00
	GSK20-120	3,5-20	97,5	48,5	50	50	120	221,75	GSK20	4,40
	GSK20-150	3,5-20	97,5	48,5	50	50	150	251,75	GSK20	5,00
	GSK20-200	3,5-20	97,5	48,5	50	50	200	301,75	GSK20	5,50
	GSK25-100	16,0-25,4	97,5	48,5	56,1	56,1	100	201,75	GSK25	4,10
	GSK25-120	16,0-25,4	97,5	48,5	56,1	56,1	120	221,75	GSK25	4,50
	GSK25-150	16,0-25,4	97,5	48,5	56,1	56,1	150	251,75	GSK25	5,10
	GSK25-200	16,0-25,4	97,5	48,5	56,1	56,1	200	301,75	GSK25	5,81

**Hinweise:** Preis inkl. Spannmutter. Spannzange und –Schlüssel müssen separat bestellt werden.  
**Notice:** Price includes hex nut. Collet and wrench shall be ordered separately.

**Merkmale**

- Gewuchtet: G2,5; 25,000 U/m
- Rundlauf : < 0,005 mm.

**Features**

- *Balanced: G2,5; 25,000 rpm;*
- *Runout: < 0,005 mm.*

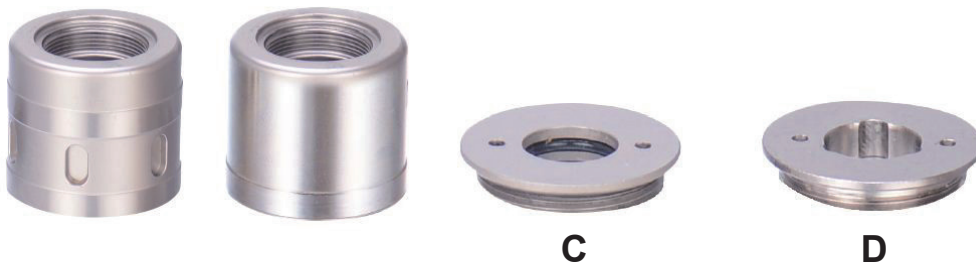
**J-Spannmutter für High-Speed Werkzeugaufnahme**  
*J-Nut for High Speed Tool Holder*

J-Spannmutter J-nut		Dichtring (Zentraler Kühlmittelzufuhr) Nut Seal (Internal cooling)	Spannschlüssel Wrench
DSK	GSK		
DSK6-J	GSK6-J	MSK6-C3 / 3.3 / 4 / 4.2 / 5 / 6	WMSK6
DSK10-J	GSK10-J	MSK10-C3 / 4 / 4.5 / 5 / 5.5 / 6 / 6.2 / 6.5 / 6.8 / 7 / 8 / 8.5 / 10	WMSK10
DSK16-J	GSK16-J	MSK16-C7 / 8 / 8.5 / 10 / 10.3 / 11 / 11.5 / 12 / 12.5 / 13.5 / 14 / 15 / 16	WMSK16
DSK20-J	GSK20-J	MSK20-C8 / 10 / 12 / 16 / 17.5 / 20	WMSK20
DSK25-J	GSK25-J	MSK25-C8 / 10 / 12 / 16 / 17 / 17.5 / 18 / 20 / 25	WMSK25

J-Spannmutter J-nut		Dichtring (seitlicher Kühlmittelzufuhr über den Bund) Nut Seal (Flange Cooling)	Spannschlüssel Wrench
DSK	GSK		
DSK6-J	GSK6-J	MSK6-D3 / 3.3 / 4 / 4.2 / 5 / 6	WMSK6
DSK10-J	GSK10-J	MSK10-D3 / 4 / 4.5 / 5 / 5.5 / 6 / 6.2 / 6.5 / 6.8 / 7 / 8 / 8.5 / 10	WMSK10
DSK16-J	GSK16-J	MSK16-D7 / 8 / 8.5 / 10 / 10.3 / 11 / 11.5 / 12 / 12.5 / 13.5 / 14 / 15 / 16	WMSK16
DSK20-J	GSK20-J	MSK20-D8 / 10 / 12 / 16 / 17.5 / 20	WMSK20
DSK25-J	GSK25-J	MSK25-D8 / 10 / 12 / 16 / 17 / 17.5 / 18 / 20 / 25	WMSK25